

ICON

ELECTRIC DIRECT STEAM COMBI OVEN

LAINOX
DEVICE FOR COOKING

ICET051



5 x 1/1 GN - 5 x (600 x 400)

Item



IT'S ALL READY, IT TAKES ONE TOUCH

The Touch & Cook function has ten pre-programmed cooking modes. The Icon control panel is ergonomic, thanks to its easy-to-understand icons, allowing you to get started straight away and more simply.



FOR BOTH SWEET AND SAVOURY

Icon is suitable for use with all types of baking tray, for cooking and baking.



SPECIAL STEAM-COOKED DISHES.

You only need steam to create the perfect dish. No waste and maximum precision and control, even at low temperatures.



"CLIMA" HUMIDITY REGULATOR FOR GRILLING AND FRYING.

"Clima" maintains the ideal climate inside the cooking chamber by controlling both temperature and humidity.



EVERYTHING ON SHOW, EVEN THE CLEANING.

We've eliminated the separate detergent tank, by using an exclusive automatic cleaning system with 100% recyclable liquid detergent cartridges.



VARIABLE ENERGY CONSUMPTION SYSTEM.

The Ecospeed Dynamic system calibrates power levels based on the amount of food being cooked.



COOKING METHODS

- 10 pre-programmed cooking modes identifiable by instant-start icons.
- Programmable memory from mode numbers 11 to 89 in automatic sequence (up to 4 cycles).
- All programmes in the memory can be associated with any of the icons in order to create a favourites list.
- The handy memo board can be used to make a note of cooking programmes.
- Manual cooking with three cooking modes: Convection from 30°C to 260°C, Steam from 30°C to 130°C, Combined from 30°C to 260°C.
- Programming that can be used to work with 4 cycles in automatic sequence. These can be memorised for automatic cooking.
- Internal temperature controlled cooking with a probe. (optional)
- CLIMA, automatic measurement and control system for humidity levels in the cooking chamber.

OPERATION

- Electronic Touch sensitive control panel.
- High-visibility alphanumeric display.
- Button for programme management and for selecting the 4 cooking cycles, with display LED.
- On-off switch, Scroll and Push knob to select and confirm choices.
- Programmable automatic pre-heating.

ICET051

CLEANING, REGULAR MAINTENANCE

- Automatic cleaning system with automatic detergent dispenser (optional).
- Single-use alkaline liquid detergent cartridges.
- Cleaning programmes Manual, Rinse, Eco, Soft, Medium, Hard.
- Manual cleaning system with externally-connected shower head (optional).

CONTROL MECHANISMS

- Self-diagnostic operation check before and during use, with detailed description and audible fault warnings.
- Autoreverse (automatic inversion of the direction of the fan) for perfectly uniform cooking.
- Automatic chamber venting control.
- Timed LED cooking chamber lighting.
- 2 fan speeds (optional), low speed also limits the heating power.
- Internal food temperature control with 4-point sensor (optional) or probe (optional).
- Provision for SN Energy Optimisation system for electric ovens (optional).
- ECOSPEED - Based on the quantity and type of product, Icon optimises and controls the energy output, maintaining the best cooking temperature and avoiding fluctuations.
- ECOVAPOR - The ECOVAPOR system greatly reduces water and energy usage by automatically controlling the steam saturation levels in the cooking chamber.
- Software updates available via USB; to be performed only by trained service manager.

TECHNICAL BUILD CHARACTERISTICS

- Perfectly smooth cooking chamber walls with rounded edges.
- Double-glazed door with thermoreflexive tempered glass, with an air cavity to prevent heat radiation towards users and for increased efficiency.
- Internal glass with book opening for ease of cleaning.
- Left or right-hand opening handle.
- Adjustable hinges for optimal grip.
- Extractable deflector for ease of cleaning of the fan bay.
- IPX4 water jet protection.

ELECTRIC HEATING SYSTEM

- Cooking compartment heating elements of armoured INCOLOY 800 type

SAFETY FEATURES

- Cooking compartment safety thermostat
- Cooking compartment safety device for pressure built-up and depression
- Fan motor thermic protection
- Mechanical door switch
- Lack of water displayed alarm
- Self-diagnosis and fault display
- Component cooling system with overheat display control

STANDARD EQUIPMENT

- Side runners
- Cooking program memo board with pen and eraser

OPTIONAL - TO BE REQUESTED WHEN ORDERING OVEN

- Automatic cleaning system LCS, Liquid Clean System - Equipped with 1 can of detergent, 5 kg.
- Multipoint core probe. Ø 3 mm
- Needle core probe. Ø 1 mm
- 2 Speed fan: normal / reduced
- Opposite hinged door
- Double release door opening
- Configuration for connection to extraction hood
- Extra charge for pastry version shelf racks
- Extra charge for energy saving system connection

EXTRA ACCESSORIES THAT CAN BE INSTALLED FOLLOWING PURCHASE

- Kit for automatic cleaning system LCS, Liquid Clean System - Equipped with 1 can of detergent, 5 kg.
- Kit for multipoint core probe. Ø 3 mm
- Kit for needle core probe. Ø 1 mm
- Kit for 2 speed fan: normal / reduced
- Kit for opposite hinged door
- Hand shower with fittings and connections
- Fat filter

- Stainless steel floor stand
- Side runners for stand floor
- Extraction hood with air-cooled condenser - Available only for prearranged ovens
- Pair of shelf racks 600 x 400 - Pastry version
- Caster kit for floor stands, 2 with brake
- Flanged feet kit for floor stands, for marine installations
- Proofers with humidifier and digital programmables controls - Glass door

TOUCH T ELECTRONIC CONTROLS

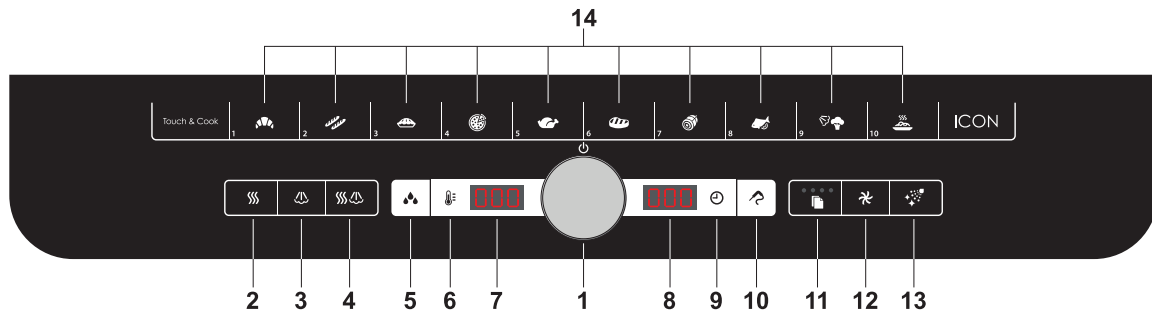

- 1 - General switch - setting/selection knob
- 2 - Convection mode button
- 3 - Steam mode button
- 4 - Combined convection/steam mode button
- 5 - Automatic moisture control activation button, manual moisture injection button
- 6 - Chamber temperature button
- 7 - Cooking chamber temperature display, moisture value display, programme/recipe display
- 8 - Cooking time display (none/set), product core temperature display (real/set), Touch & Cook button display
- 9 - Cooking time button
- 10 - Button to start cooking with core probe
- 11 - Cooking/recipe programmes button, cooking cycle settings button
- 12 - Reduced speed button
- 13 - Cleaning programme activation button
- 14 - Touch & Cook keypad

TECHNICAL DATA

Chamber capacity	GN	5 x 1/1	Total electric power	kW	7,25	
		600 x 400	5	Gas versions nominal heating output	kW / kcal	- / -
Distance between layers	mm	70	Chamber heating output	kW / kcal	7 / -	
Number of meals		30 / 80	Steam heating output	kW / kcal	- / -	
Number of croissants		60 / 80	Fan power	kW	0,2	
External dimensions	mm	812 x 725 x 770 h	Power supply voltage		AC 230	
Packing dimensions	mm	910 x 865 x 900 h			V - 50 Hz	3 AC 230
Weight - Net / Gross	kg	74 / 85				3N AC 400

ICET051

The data reported in this document is to be considered non-binding. The company reserves the right to make changes at any time, without prior notice

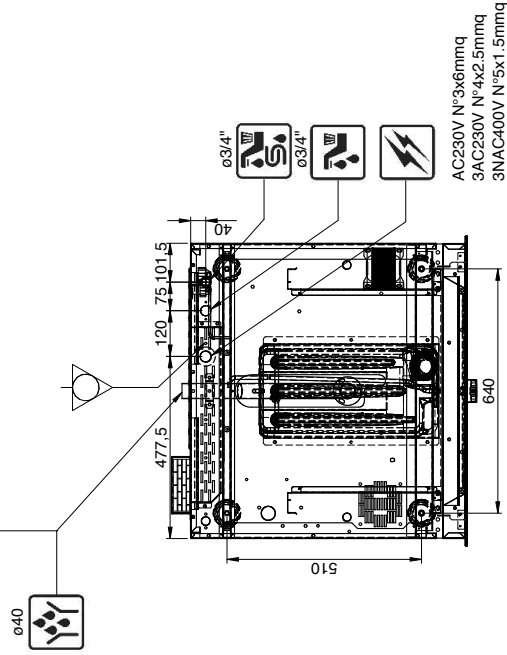
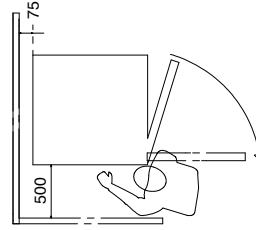
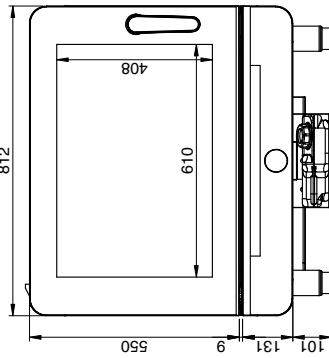
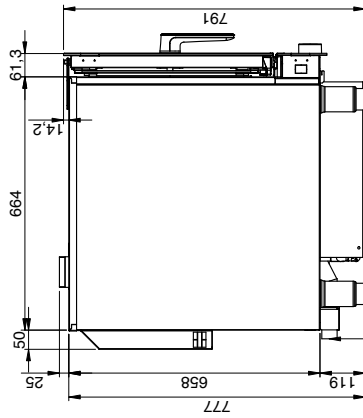
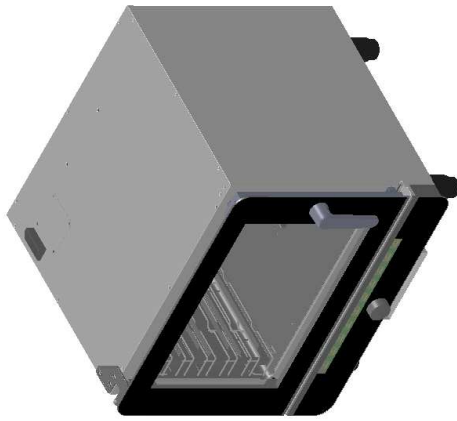

AC230V N°3x6mmq
3AC230V N°4x2.5mmq
3NAC400V N°5x1.5mmq

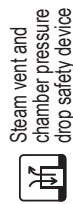

CE IPX 4

According to CE rules, gas ovens must be installed where proper evacuation of burnt gas can be provided (type B13, B23, A3)

