

FTLR-8G

65 MAGICPROF GAS GRIDDLE

Gas Fry-top 1/2 grooved + 1/2 smooth, plate
cm.75,5x55 - 2 cooking areas

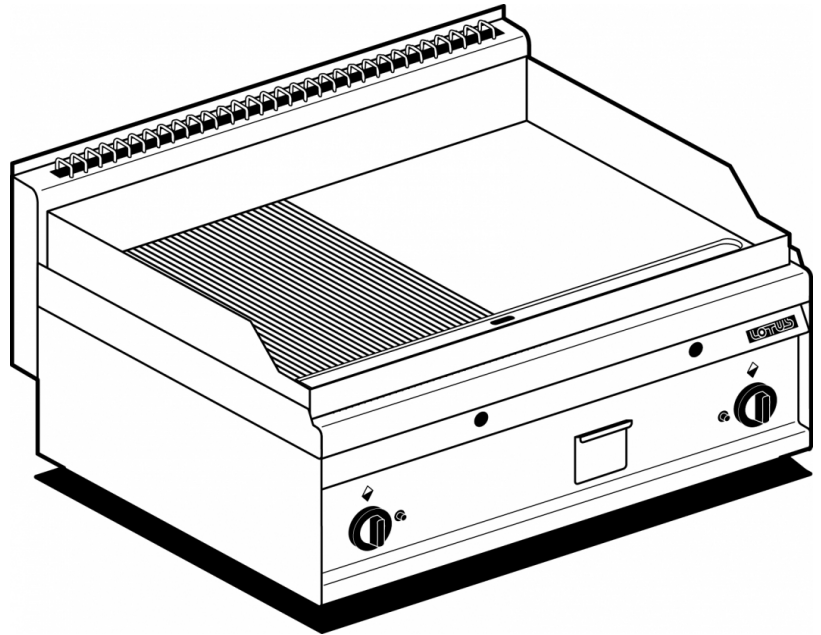

Construction - Fabricated using CrNi 18/10 AISI 304 grade Stainless Steel Scotch-Brite Satin polish Finish, incorporating 1mm thick worktop, rounded edges, chromed details and rear splash back. Model - Professional Gas Griddle, Smooth, Ribbed or 50 / 50, Normal or Chrome. Normal Plate in FE430B Steel and Chrome in FE510C Steel. High durability and rapid heat up. Burners with Piezoelectric ignition and pilot light, 50 - 300degC control, thermostatic and thermocouple safety valves, Removable liquid containers. Maintenance - All serviceable parts are accessible by the easy removal of front control panel. Fittings - Appliance is supplied with both LPG and Natural Gas conversion jets and adjustable feet.

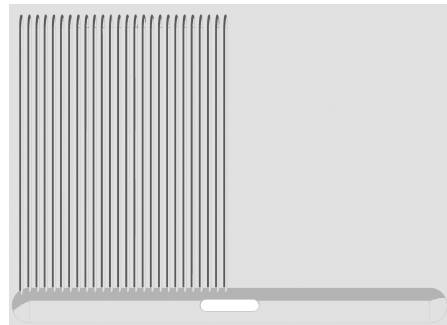

ITALIAN CULINARY ART

The pictures are purely representative. The manufacturer reserves the right to modify the technical data and models without previous notice.

FTLR-8G

65 MAGICPROF
GAS GRIDDLE

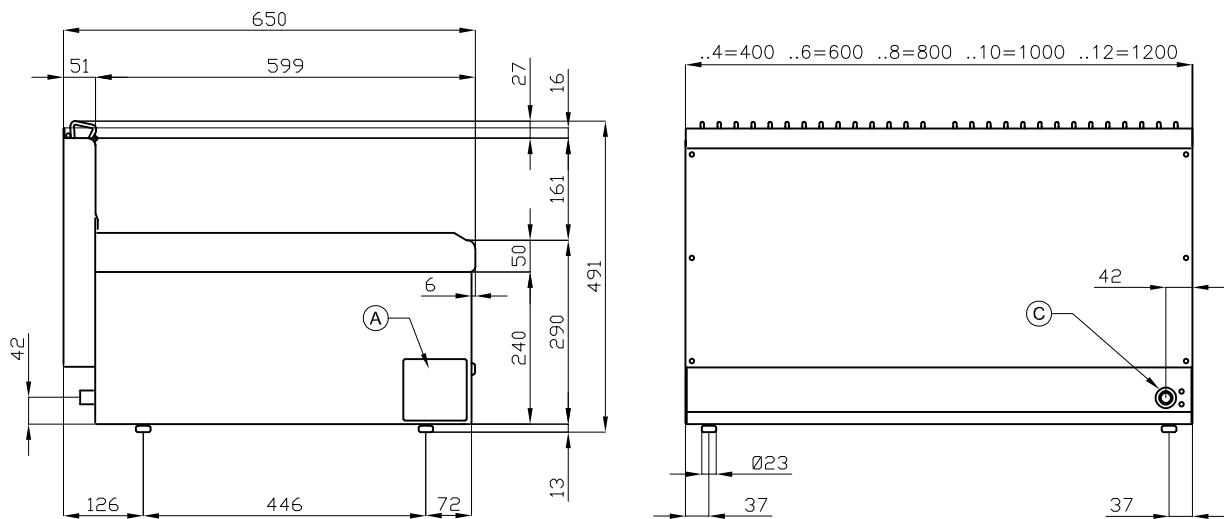

A	Data plate	C	Gas connection	ISO 7-1 1/2" M
---	------------	---	----------------	----------------

MODEL: FTLR-8G
DIMENSIONS: cm. 80x 65x 29h
GAS POWER: 14 kW / 12.040 kcal/h
GAS TYPE: Natural Gas / LPG



kg: 84
m³: 0.349
mm: 830x690x610

BUY LOTUS BUY ITALY

The pictures are purely representative. The manufacturer reserves the right to modify the technical data and models without previous notice.



LOTUS S.P.A. Via Calmaor, 46
31020 San Vendemiano(TV) - Italy
Tel. + 39 0438 778020 / 778468
Fax + 39 0438 778277
www.lotuscookers.it - lotus@lotuscookers.it