

# FTL-6ET

## 65 MAGICPROF ELECTRIC GRIDDLE

Electric Fry-top smooth griddle, plate  
cm.55,5x55 - 2 cooking areas

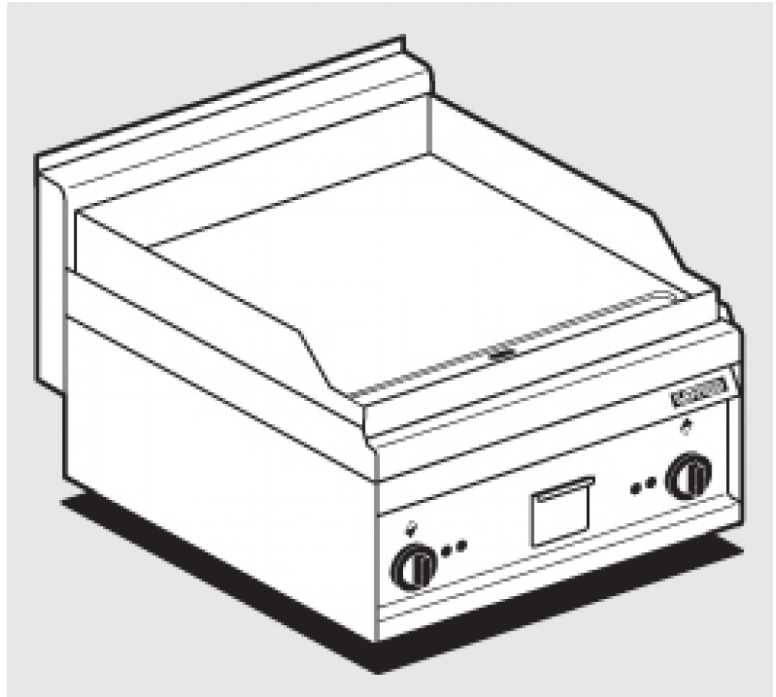

Construction - Fabricated using CrNi 18/10 AISI 304 grade Stainless Steel Scotch-Brite Satin polish Finish, incorporating 1mm thick worktop, rounded edges, chromed details and rear splash back. Model - Professional Electric Griddle, Smooth, Ribbed or 50 / 50, Normal or Chrome. Normal Plate in FE430B Steel and Chrome in FE510C Steel. Double thermostat, operating and safety. High durability and rapid heat up. 50 - 300degC control, Removable liquid containers. Maintenance - All serviceable parts are accessible by the easy removal of front control panel. Fittings - Appliance is supplied with adjustable feet.

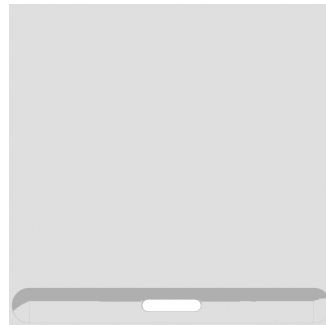

ITALIAN CULINARY ART

The pictures are purely representative. The manufacturer reserves the right to modify the technical data and models without previous notice.

# FTL-6ET

65 MAGICPROF  
ELECTRIC GRIDDLE

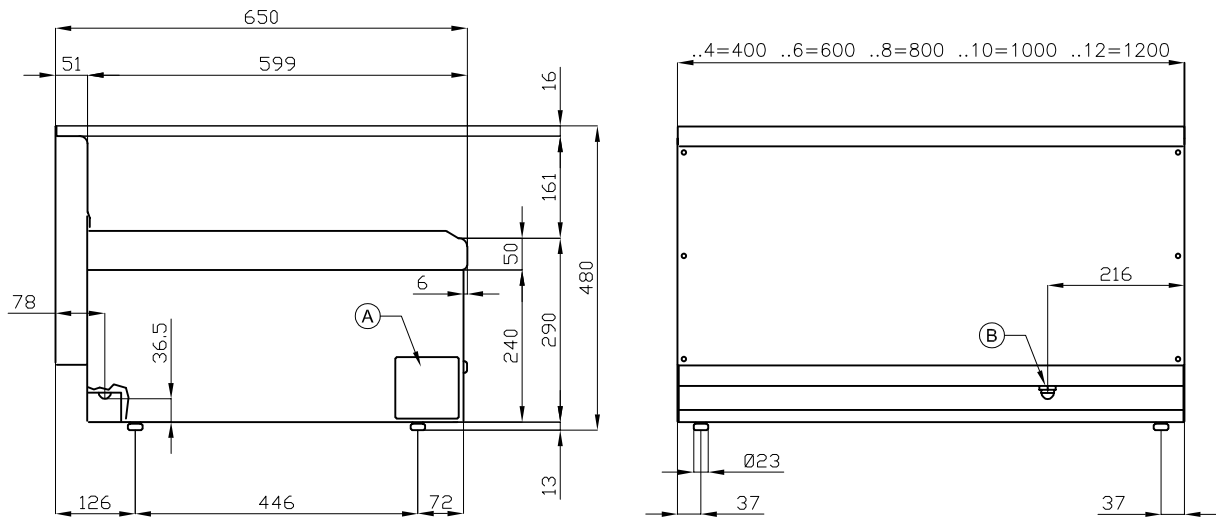

A	Data plate		B	Electrical connection	
---	------------	--	---	-----------------------	--

MODEL: FTL-6ET  
 DIMENSIONS: cm. 60x 65x 29h  
 ELECTRIC POWER: 6 kW  
 VOLTAGE: 400V~3N / 230V~3 / 230V~  
 FREQUENCY: 50/60 Hz



kg: 66.5  
 m<sup>3</sup>: 0.265  
 mm: 630x690x610

BUY LOTUS BUY ITALY

The pictures are purely representative. The manufacturer reserves the right to modify the technical data and models without previous notice.



LOTUS S.P.A. Via Calmaor, 46  
 31020 San Vendemiano (TV) - Italy  
 Tel. + 39 0438 778020 / 778468  
 Fax + 39 0438 778277  
 www.lotuscookers.it - lotus@lotuscookers.it