

# FQM-4G

## 65 MAGICPROF GAS FRYERS

Gas fryer on cabinet - Tank capacity 15  
lts.cm. 33x38x38h - Basket cm. 30x33x12h  
Production: 15 kg/h - Drip tray with sieve



**Construction** - Fabricated using CrNi 18/10 AISI 304 grade Stainless Steel Scotch-Brite Satin polish Finish, incorporating 1mm thick worktop, rounded edges, chromed details and rear splash back. **Model** - Professional Gas Fryer on cabinet. With single tank to include both basket and lid, tank filter with basket support. Burner with Piezoelectric ignition and pilot light, thermostatic and thermocouple safety valves. **Maintenance** - All serviceable parts are accessible by the easy removal of front control panel. **Fittings** - Appliance is supplied with both LPG and Natural Gas conversion jets and adjustable feet. Oil filter drain pan included.



ITALIAN CULINARY ART

The pictures are purely representative. The manufacturer reserves the right to modify the technical data and models without previous notice.

# FQM-4G

65 MAGICPROF  
GAS FRYERS

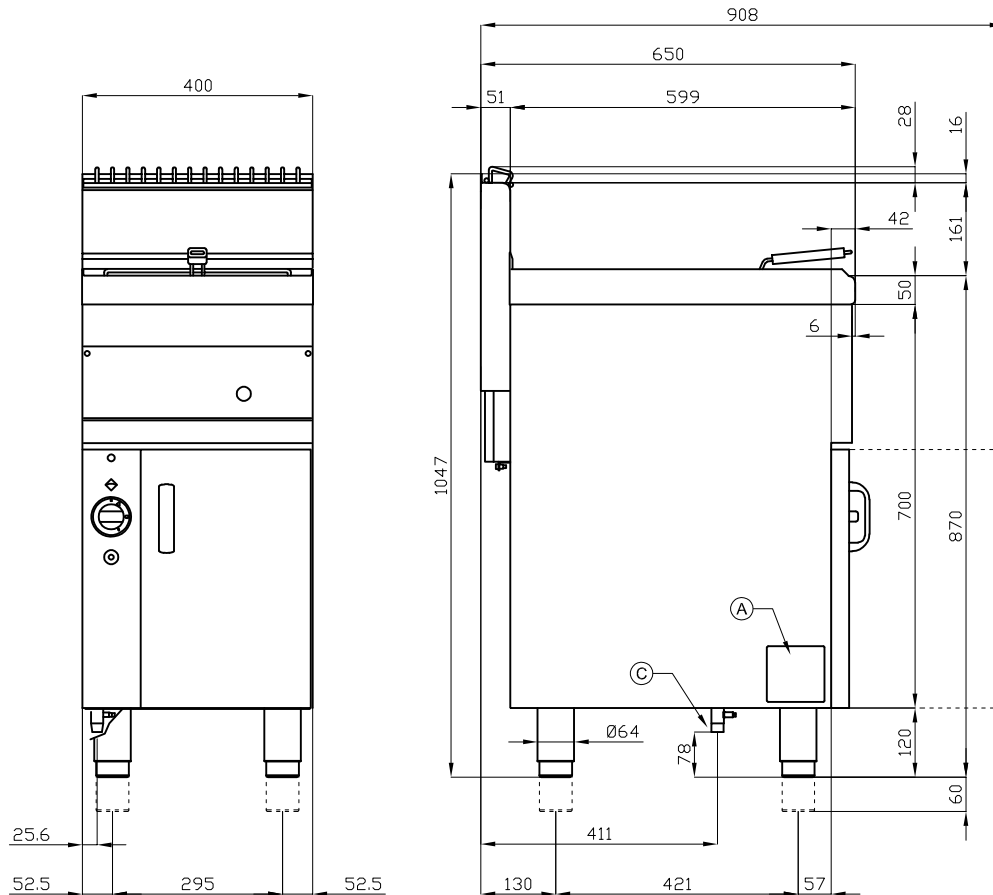

A	Data plate	C	Gas connection	ISO 7-1 1/2" M
---	------------	---	----------------	----------------

MODEL: FQM-4G  
 DIMENSIONS: cm. 40x 65x 87h  
 GAS POWER: 13,5 kW / 11.650 kcal/h  
 GAS TYPE: Natural Gas / LPG

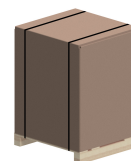

kg: 60  
 m<sup>3</sup>: 0.404  
 mm: 430x770x1220

BUY LOTUS BUY ITALY

The pictures are purely representative. The manufacturer reserves the right to modify the technical data and models without previous notice.



LOTUS S.P.A. Via Calmaor, 46  
 31020 San Vendemiano (TV) - Italy  
 Tel. + 39 0438 778020 / 778468  
 Fax + 39 0438 778277  
 www.lotuscookers.it - lotus@lotuscookers.it