

FQ-6G

65 MAGICPROF GAS FRYERS

Gas fryer - 2 tanks capacity 10 lts.
cm.22x35x25h 2 baskets cm. 20x30x10h -
Production: 20 kg/h



Construction - Fabricated using CrNi 18/10 AISI 304 grade Stainless Steel Scotch-Brite Satin polish Finish, incorporating 1mm thick worktop, rounded edges, chromed details and rear splash back. Model - Professional Gas Fryer. With single or Double tank to include both basket and lids, tank filter with basket support. Burners with Piezoelectric ignition and pilot light, thermostatic and thermocouple safety valves. Front oil drain. Maintenance - All serviceable parts are accessible by the easy removal of front control panel. Fittings - Appliance is supplied with both LPG and Natural Gas conversion jets and adjustable feet.



ITALIAN CULINARY ART

The pictures are purely representative. The manufacturer reserves the right to modify the technical data and models without previous notice.

FQ-6G

65 MAGICPROF
GAS FRYERS

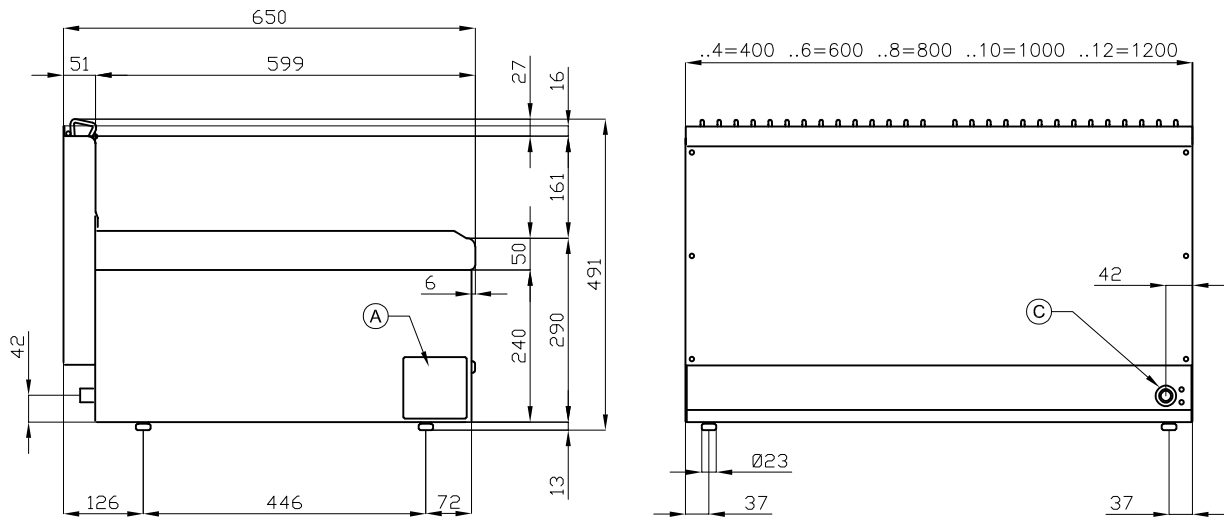

A	Data plate		C	Gas connection	ISO 7-1 1/2" M
---	------------	--	---	----------------	----------------

MODEL: FQ-6G
 DIMENSIONS: cm. 60x 65x 29h
 GAS POWER: 14 kW / 12.040 kcal/h
 GAS TYPE: Natural Gas / LPG



kg: 48.5
 m³: 0.265
 mm: 630x690x610

BUY LOTUS BUY ITALY

The pictures are purely representative. The manufacturer reserves the right to modify the technical data and models without previous notice.



LOTUS S.P.A. Via Calmaor, 46
 31020 San Vendemiano(TV) - Italy
 Tel. + 39 0438 778020 / 778468
 Fax + 39 0438 778277
 www.lotuscookers.it - lotus@lotuscookers.it