

FQ-6ET

65 MAGICPROF ELECTRIC FRYERS

Fryer threephase - 2 Tanks capacity 10 lts.
cm. 22x35x22h - 2 Baskets cm. 20x30x10h -
Production 20 kg/hr



Construction - Fabricated using CrNi 18/10 AISI 304 grade Stainless Steel Scotch-Brite Satin polish Finish, incorporating 1mm thick worktop, rounded edges, chromed details and rear splash back. Model - Professional Electric Fryer. With single or Double tank to include both basket and lids, tank filter with basket support. Double Thermostat for operating and over heat safety. Front oil drain. Maintenance - All serviceable parts are accessible by the easy removal of front control panel. Easy tank cleaning by rotating heating element. Fittings - Appliance is supplied with adjustable feet.



ITALIAN CULINARY ART

The pictures are purely representative. The manufacturer reserves the right to modify the technical data and models without previous notice.

FQ-6ET

65 MAGICPROF
ELECTRIC FRYERS

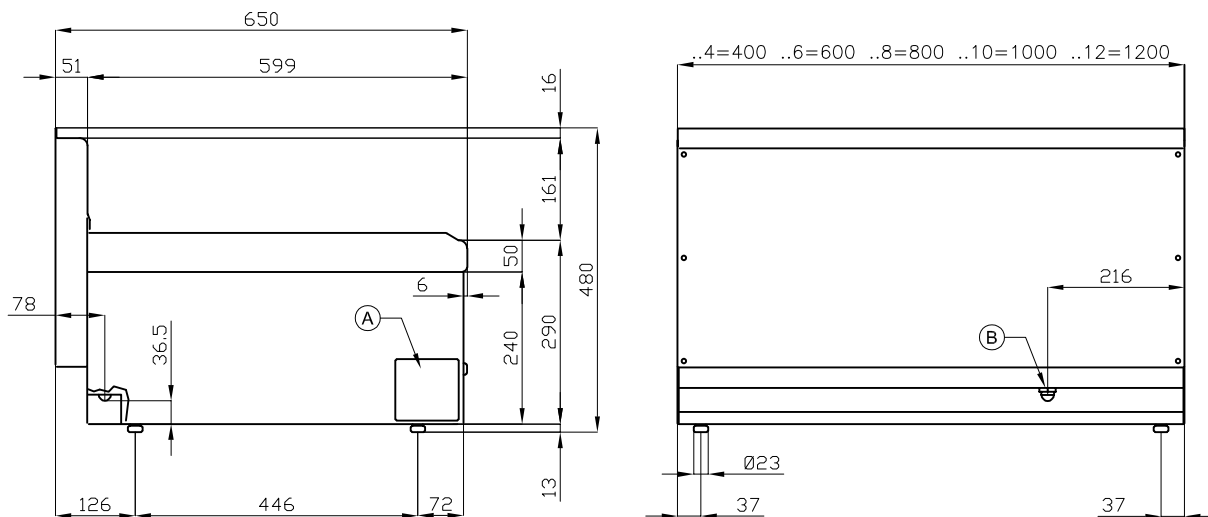

A	Data plate		B	Electrical connection	
---	------------	--	---	-----------------------	--

MODEL: FQ-6ET
 DIMENSIONS: cm. 60x 65x 29h
 ELECTRIC POWER: 14,3 kW
 VOLTAGE: 400V~3N
 FREQUENCY: 50/60 Hz



kg: 41.5
 m³: 0.265
 mm: 630x690x610

BUY LOTUS BUY ITALY

The pictures are purely representative. The manufacturer reserves the right to modify the technical data and models without previous notice.



LOTUS S.P.A. Via Calmaor, 46
 31020 San Vendemiano(TV) - Italy
 Tel. + 39 0438 778020 / 778468
 Fax + 39 0438 778277
 www.lotuscookers.it - lotus@lotuscookers.it