

# F2/8T-74G

## 70 SUPERLOTUS TOP GAS FRYERS - TOP



Gas Fryer 8+8 lts - 2 pans cm. 15x35x23h 2 baskets cm. 12x30x9,5h. Sieve and lid for pan. Production: 12 kg/h (included 1 Head end filler strip mod.TPA-7)



**Construction** - Fabricated using CrNi 18/10 AISI 304 grade Stainless Steel Scotch-Brite Satin polish Finish, incorporating 2 mm thick worktop, rounded edges, chromed details and rear splash back. Knobs with waterproof grades IPX5. **Model** - Professional Gas Fryer. With single or Double tank to include both basket and lids, tank filter with basket support. Burners with Piezoelectric ignition and pilot light, thermostatic and thermocouple safety valves. Front oil drain. **Maintenance** - All serviceable parts are accessible by the easy removal of front control panel. **Fittings** - Appliance is supplied with both LPG and Natural Gas conversion jets and adjustable feet.



ITALIAN CULINARY ART

The pictures are purely representative. The manufacturer reserves the right to modify the technical data and models without previous notice.

# F2/8T-74G

70 SUPERLOTUS TOP  
GAS FRYERS - TOP

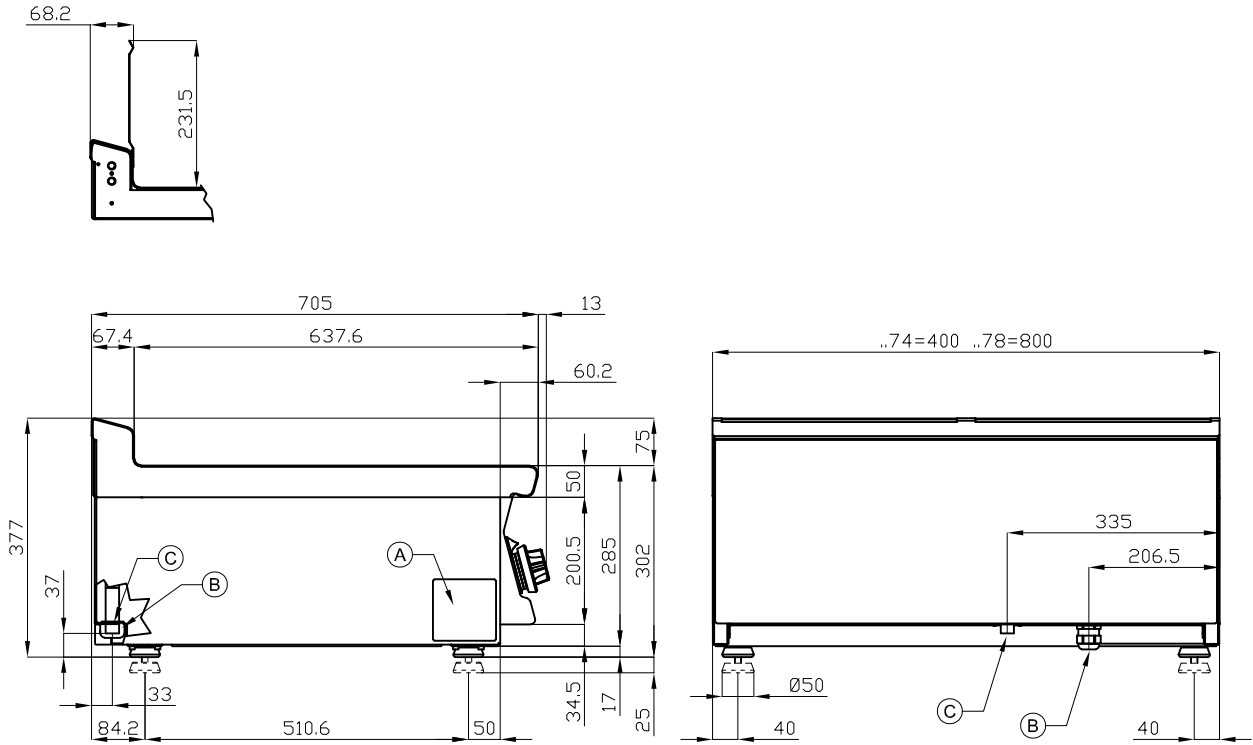

A	Data plate	C	Gas connection	ISO 7-1 1/2" M
---	------------	---	----------------	----------------

**MODEL:** F2/8T-74G  
**DIMENSIONS:** cm. 40x 70,5x 28h  
**GAS POWER:** 9 kW / 7.740 kcal/h  
**GAS TYPE:** Natural Gas / LPG

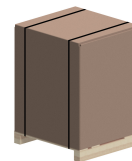

**kg:** 50  
**m<sup>3</sup>:** 0.179  
**mm:** 430x770x540

BUY LOTUS BUY ITALY

The pictures are purely representative. The manufacturer reserves the right to modify the technical data and models without previous notice.



LOTUS S.P.A. Via Calmaor, 46  
 31020 San Vendemiano(TV) - Italy  
 Tel. + 39 0438 778020 / 778468  
 Fax + 39 0438 778277  
 www.lotuscookers.it - lotus@lotuscookers.it